

# SAUNALAHTI KOTIKUITU: INTERNET ACTIVATION

## Connections in the home distributor

We will open an Internet connection to your apartment's distribution box, which is usually located in or close to your home's electrical cabinet.

### Using the Internet via a cable in a single room

You need a network cable with an RJ-45 connector.

Data sockets in each room have been marked with numbers and the words DATA or ATK. You can find corresponding markings in the distribution box.

Connections are made using a network cable. Do as follows:

1. In your distribution box, connect the cable to the socket where the Internet connection enters your home. The socket is marked with the word ATK, data, jakamo, or similar. (A).
2. In your distribution box, connect the other end of the cable to the socket in the room in which you wish to use your Internet connection (B). The socket in the distribution box is marked similarly to the socket in the specific room.

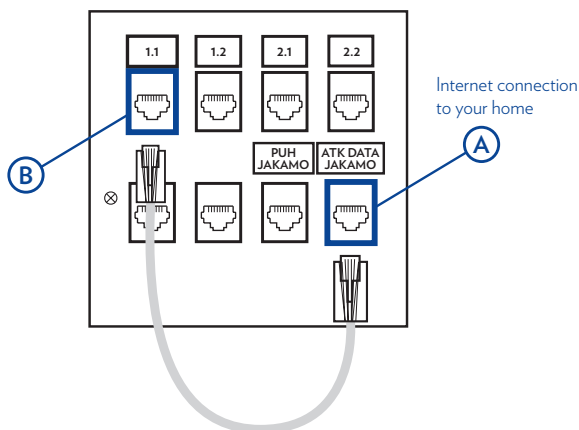

**Tip:** If you do not know which socket in the distribution box connects your home to the Internet, you can identify the correct socket by connecting your computer directly to the distribution box via a cable and by testing which socket is connected to the Internet.

### Using the Internet in several rooms

You need a router or switch and network cables with RJ-45 connectors. Do as follows:

1. In your distribution box, connect the cable to the socket where the Internet connection enters your home. The socket is marked with the word ATK, data, jakamo, or similar. (A).
2. Connect the other end of the cable to the socket on your router marked WAN (B).
3. Use cables to connect the LAN and ETHERNET sockets of your router (C) and the distribution box sockets of the rooms (D) where you want to use your Internet connection.

We recommend that you use routers approved by Elisa and supplied with illustrated instructions. You can acquire your router from any Elisa shop or through the OmaElisa service.

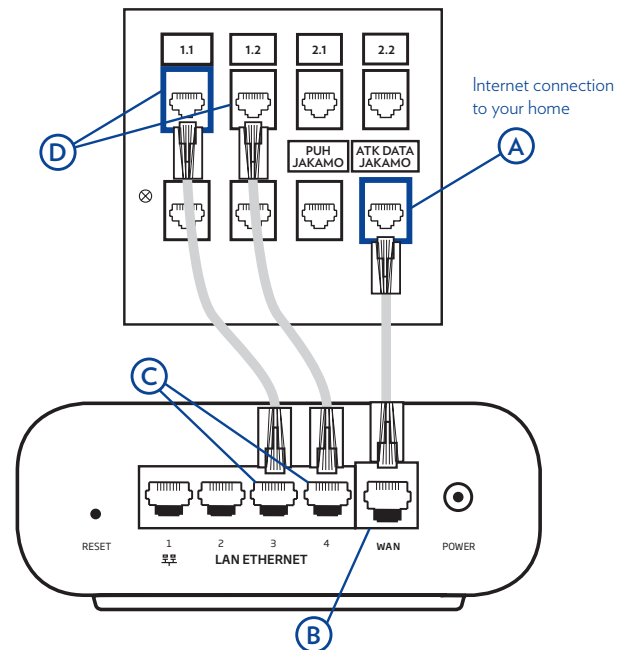

## Using the Internet wirelessly (WLAN)

You need a wireless router and network cables with RJ-45 connectors. Follow these instructions:

1. In your distribution box, connect the cable to the socket where the Internet connection enters your home. The socket is marked with the word ATK, data, jakamo, or similar. (A).
2. In your distribution box, connect the other end of the cable to the socket of the room in which you wish to place your wireless router (B). The socket in the distribution box is marked similarly to the socket in the specific room.
3. Connect the router to the specific room's socket according to the instructions delivered with the device.

To configure the wireless settings for your router, please visit [elisa.fi/asiakaspalvelu](http://elisa.fi/asiakaspalvelu)

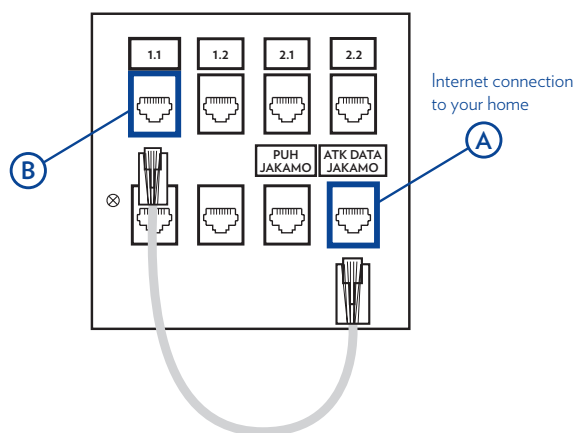

You can acquire your router from any Elisa shop ([elisa.fi/myymalat](http://elisa.fi/myymalat)) or through our webshop [elisa.fi/kauppa](http://elisa.fi/kauppa)

## THIS IS HOW YOU CAN CONTACT US

We are continuously developing new ways to serve our customers – select the most suitable contact method here!

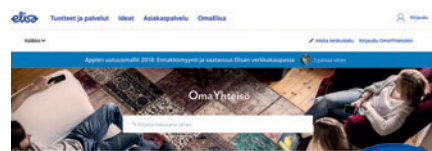

### OmaYhteisö

The OmaYhteisö chat site is full of lively discussions of Saunalahti and Elisa products and services. You can find topics that interest you using the search function, and you can mark useful answers as helpful by clicking them. It is also available on Facebook.

[yhteiso.elisa.fi](http://yhteiso.elisa.fi)  
[facebook.com/elisasuomi](https://www.facebook.com/elisasuomi)

Ask, help,  
discuss!

elisa  
OMAGURU

### Elisa Omaguru

Omaguru helps you in the installation and use of all kinds of technical appliances and when facing a problem. Through the Kotituki service, you can get an expert to install your devices in your home. Do not forget about the domestic help tax credit.

**omaguru.fi**  
 Call Omaguru at **+358 600 900 500**  
 (€2.28/min + local/mobile call charge)  
 Mon–Fri at 8 am – 9 pm, Sat at 9 am – 5 pm).

Expert and  
friendly  
service!



### OmaElisa

In OmaElisa, you can find your Elisa and Saunalahti subscriptions, manage your wireless network settings, check your invoices and apply for a payment extension for your invoices.

**omaelisa.fi**

You can also  
log in using an  
Elisa mobile  
certificate

## Also remember:

- The customer support site offers help and instructions. [elisa.fi/asiakaspalvelu](http://elisa.fi/asiakaspalvelu)
- You can call our customer service **+358 10 190 240** (local/mobile call charge, Mon–Fri at 8 am – 6 pm, fault notifications Mon–Fri 24 hours, local/mobile call charge).

