

# DEPLOYMENT OF THE CABLE MODEM FOR SAUNALAHTI KOTIKUITU

Thank you for choosing Elisa's Saunalahti Kotikuitu broadband. This guide tells you how to activate your new broadband connection easily. The cable modem is connected to the building and the flat via Elisa's cable network.

You need a modem supporting the EuroDOCSIS 3.0 standard to use your broadband. If you are already using a modem, give the MAC address indicated on the label on the bottom of the modem to Elisa.

## Installing your modem and activating your subscription

1. Connect the antenna cable delivered with the cable modem to the threaded antenna connector of the modem. If you need to use the same antenna socket for your television or digital receiver, use an antenna splitter.
2. Connect the modem power cable to the modem and connect the power plug to a wall socket.
3. Finally, turn on the modem. Leave the modem on to establish a connection.

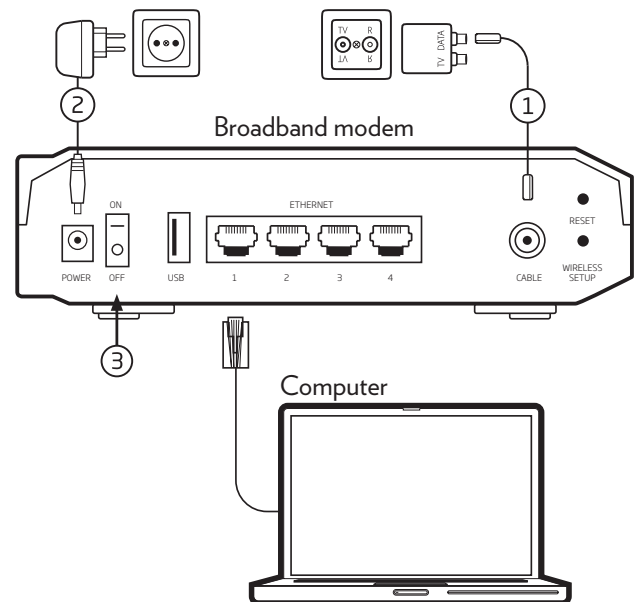

When started for the first time, establishing the connection may take several hours. When the internet light or the upstream and downstream lights of the modem are lit, you can start using the internet connection. If the connection has not been established after three hours, restore the factory settings of the modem according to its user guide and try again.

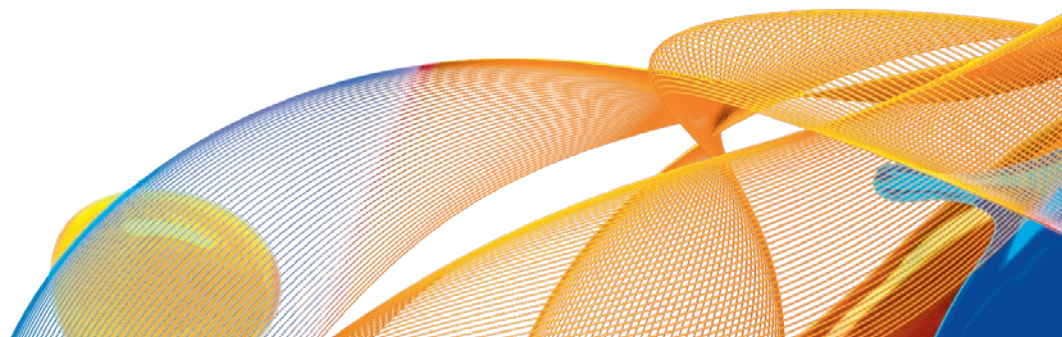

## Using your broadband

You can connect, for instance, a computer or a game console to the modem by connecting a network cable to the LAN or ETHERNET connectors. To use your broadband via a wireless network (WLAN), e.g. on your laptop or tablet, you need a modem equipped with a wireless base station or a separate base station.

**The cable modem delivered by Elisa is equipped with a secure wireless base station.** The name and password of the wireless network are indicated on the label on the bottom of the modem. You can also manage your wireless network settings in OmaElisa at **omaelisa.fi**. You can get help to define and use the settings of your modem at **elisa.fi/asiakaspalvelu**. Our Omaguru experts can assist you personally.

Elisa's Omaguru service helps you in all problems related to technical household devices. Read more about the service at **elisa.fi/omaguru/en** or call **+358 600 900 500** (EUR 2.28 per minute + local/mobile charge).

## HOW TO CONTACT US

We are continuously developing new ways to serve our customers – select the most suitable contact method here!

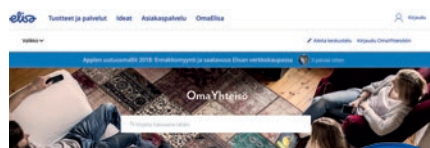

### OmaYhteisö

The OmaYhteisö chat site is full of lively discussions of Elisa products and services. You can find topics that interest you by using the search function, and you can mark useful answers as helpful by clicking them. OmaYhteisö is also available on Facebook.

**yhteiso.elisa.fi**  
**facebook.com/elisasuomi**

Ask, help,  
discuss!

**elisa**  
OMAGURU

### Elisa Omaguru

Omaguru helps you in the installation and use of all kinds of technical appliances and when facing a problem. Through the Kotituki service, you can get an expert to install your devices in your home. And don't forget about the domestic help tax credit!

**elisa.fi/omaguru/en**  
You can call a guru at **+358 600 900 500** (EUR 2.28 per minute + local/mobile charge) on weekdays 8 am–9 pm and Saturdays 9 am–5 pm.

Expert  
and friendly  
service.



### OmaElisa

In OmaElisa, you can find your Elisa subscriptions, manage your wireless network settings, check your invoices and apply for a payment extension for your invoices.

**omaelisa.fi**

You can also  
log in using an  
Elisa mobile  
certificate

## Good to remember:

- The customer service site offers help and instructions. **elisa.fi/asiakaspalvelu**
- You can call our customer service at **+358 10 190 240** (local/mobile charge) on weekdays 8 am–6 pm and Saturdays 10 am–4:30 pm, fault notifications 24/7 (local/mobile charge).

